

## SC16 2016

### Cabinet



#### Materials:

CARCASS: blockboard panels veneered in Abonos fossil oak or smoked oak, finished with transparent water-based or solvent-based coating. 45° edges in solid wood (Abonos fossil oak or smoked oak).

DRAWERS: blockboard, veneered in Abonos fossil oak or smoked oak, finished with transparent water-based or solvent-based coating. Installed on runners with soft-close system.

DRAWER FRONT PANELS: blockboard veneered in Abonos fossil oak or smoked oak, finished with transparent water-based or solvent-based coating. Or in sheet in striped brass, grey striped steel or dark délabré steel. 45° edge and handle in solid wood.

TOP: blockboard veneered in Abonos fossil oak or smoked oak, finished with transparent water-based or solvent-based coating. Or internal panel in structural aluminium covered by sheet in striped brass, grey striped steel or dark délabré steel. Or in Grey Stone marble, white Carrara marble or Calacatta Oro, hand finished and treated with water repellent products. Or in MDI composite. Lower reinforcement made of fibreglass mesh, embedded in epoxy resins.

BASE: matt black powder-coated steel and feet in burnished steel. Adjustable thermoplastic glide foot.

FEET: burnished steel. Adjustable thermoplastic glide foot.

Cabinets with feet.

M75

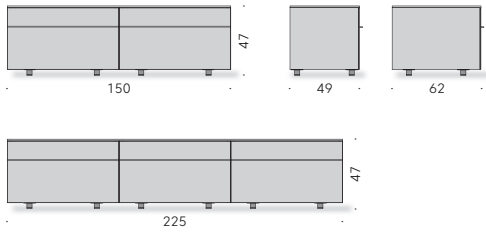

M90

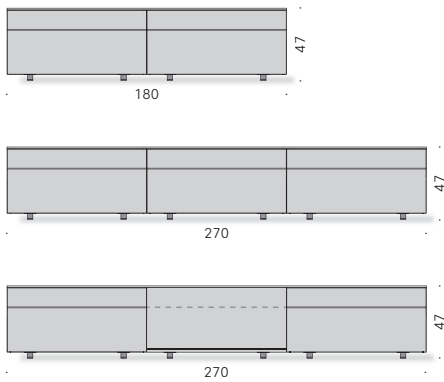

M120

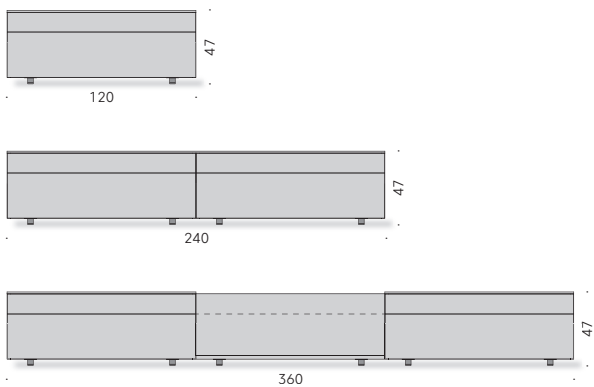

Cabinets with base.

M75

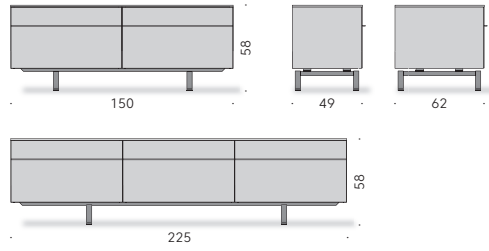

M90

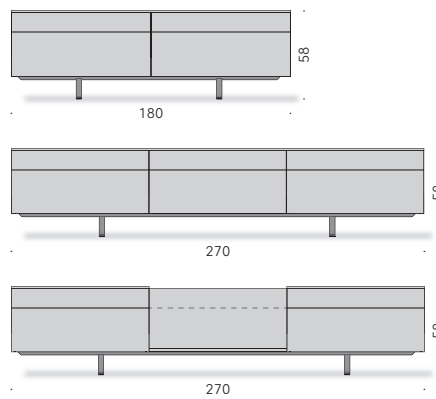

M120

